

Development and Ergonomic Assessment of Manually Operated Modified Linseed Crop Thresher for Studying the Physical Properties of the Linseed Seed

**Naveendra Kumar Patel ^{aω*}, Sheen Cline Moses ^{a#}, Rana Noor Aalam ^{a†}
and Prashant M. D'souza ^{b‡}**

^a Department of Farm Machinery and Power Engineering, VIEAT, SHUATS, Prayagraj, U.P., India.

^b Department of Renewable Energy Engineering, VIEAT, SHUATS, Prayagraj, U.P., India.

Authors' contributions

This work was carried out in collaboration among all authors. All authors read and approved the final manuscript.

Article Information

DOI: 10.9734/IJECC/2022/V12i111348

Open Peer Review History:

This journal follows the Advanced Open Peer Review policy. Identity of the Reviewers, Editor(s) and additional Reviewers, peer review comments, different versions of the manuscript, comments of the editors, etc are available here: <https://www.sdiarticle5.com/review-history/92686>

Original Research Article

Received 05 August 2022

Accepted 08 October 2022

Published 10 October 2022

ABSTRACT

The study took place at SHUATS, Prayagraj (U.P), India, 210203. Studying the physical properties of linseed were studied for two varieties SHUATS Alsi-2 and Neelam, with moisture contents (d.b) of 7.473%, 10.786%, and 14.03%. The average number of capsules per plant was found to be 36.88. The average number of seeds per capsule was found to be 8.12. Linseed's length, width, and thickness were measured to be 8.11, 6.94, and 6.87 mm, respectively. The geometric mean diameter was measured at 7.288 mm. The linear dimensions of the seed were discovered to be an average of 5.308mm, width 2.507mm, and thickness 0.964mm for the SHUATS Alsi-2 variety, and an average of 5.214mm, width 2.448mm, and thickness 0.903 for the Neelam variety. The SHUATS Alsi-2 variety had an average AMD of 2.924mm and a GMD of 2.338mm, whereas the Neelam variety had an average AMD of 2.855mm and a GMD of 2.258mm. The average surface area, sphericity, and volume for the SHUATS Alsi-2 variety were 17.218mm², 0.441, and

^ωPhD Scholar;

[#]Professor and Head;

[†]Research Engineer;

[‡]Assistant Professor;

*Corresponding author: E-mail: nkp7378@gmail.com;

6.741mm³, respectively, whereas the average surface area, sphericity, and volume for the Neelam variety were 16.0403mm², 0.433, and 6.047mm³. It was also discovered that the mean 7.656gram 1000 grain weight for the linseed variety in SHUATS Alsi-2 and the mean 8.0153gram 1000 grain weight for the linseed variety in Neelam were different. The SHUATS Alsi-2 variety had an average bulk density of 626.64 kg/m³, a true density of 1139.553 kg/m³, and a porosity of 44.847, whereas the Neelam variety had an average bulk density of 673.354 kg/m³, a true density of 1126.174 kg/m³, and a porosity of 40.135.

Keywords: Linseed; capsules; moisture content; linear dimensions; density.

1. INTRODUCTION

Linseed (*Linum usitatissimum*) belongs to the genus *Linum* and the family *Linaceae*. *Jawas* and *Alsi* are the local names for it. In central India, it is a prominent oilseed crop. Linseed is regarded as one of the most important commercial yarn crops. Linseed blossoms contain a cluster of five pale blue petals. The fruit is made up of spherical capsules. The seeds are round, somewhat flattened, pale to dark brown, and lustrous. Linseed is produced for both seed and fiber production. Fabric, dye, paper, lubrication, soap, fishing nets, and medicines are all made from the linseed plant. It is one of the oldest crops grown by humans for grain and fiber. It has been cultivated since antiquity for the production of flax (fiber) and seeds. Every part of the linseed plant is economically used, either directly or indirectly. Linseed has received a lot of attention in recent years because of its nutritional content, which has a positive effect on disease prevention by providing health-promoting components such as alfa linolenic acid, lignin, and polysaccharides; essential amino acids, carbohydrates, vitamins, minerals, crude fiber, and this is the best herbal source of omega-3 and omega-6 fatty acids. Diets high in fiber have been shown to reduce the risk of heart disease, diabetes, colorectal cancer, obesity, and inflammation [1]. It has happened. Linseed has the highest concentration of the omega-3 fatty acid Alpha Linolenic Acid (ALA) of any oilseed crop. Kazakhstan, Russia, Canada, China, the United States of America, India, Ethiopia, Afghanistan, France, and the United Kingdom of Great Britain are the top ten producing countries in 2019. In 2019, India is ranked sixth among linseed producing countries. Major linseed producing states in the country include Madhya Pradesh, Karnataka, Chhattisgarh, Jharkhand, Bihar, Maharashtra, Odisha, Uttar Pradesh, West Bengal, and Assam. Madhya Pradesh and Uttar Pradesh jointly produce around 70% of the national linseed production. The study of the grain's physical properties, such as its linear

dimension, volume, surface area, density, porosity, and hardness, are important in many of the problems associated with the design of a particular machine. Without an understanding of the material's physical characteristics, it is impossible to fully appreciate the theoretical performance of the machines and mechanisms utilised in the mechanical handling and processing of material [2].

2. MATERIALS AND METHODS

The SOLIDWORKS drawing of a linseed crop thresher was generated. The modified linseed crop thresher was created at the Farm Machinery and Power Engineering workshop at VIAET, SHUATS Prayagraj.

Linseed was physically cleaned to remove any foreign contaminants such as dust, dirt, broken or immature seeds. The original moisture content of the seeds was evaluated by drying them in a hot air oven at 105 °C for 24 hours. Using the usual hot air oven method and the following calculation, the initial moisture content of the seed was measured [3].

$$MC (\%) = \frac{W_2 - W_3}{W_3 - W_1} \times 100$$

Where, MC is the Moisture content on a dry basis, %; W_1 is the initial weight of the bowl in grams; W_2 is the sample weight before drying + bowl weight in grams; W_3 is the sample weight after drying + bowl weight in grams.

Using the following equation and careful mixing, Sacilink et al. [4] made seed samples with the right amount of moisture by adding the amount of distilled water that was calculated and mixing them well.

$$Q = \frac{m_f - m_i}{100 - m_f} \times w_i$$

Where Q is the weight of the water to be added in grams, w_i is the initial weight of the seed sample in grams, m_i is the initial moisture content of the seed sample on percentages dry basis, and m_f is the final moisture content of the seed sample in percentages dry basis.

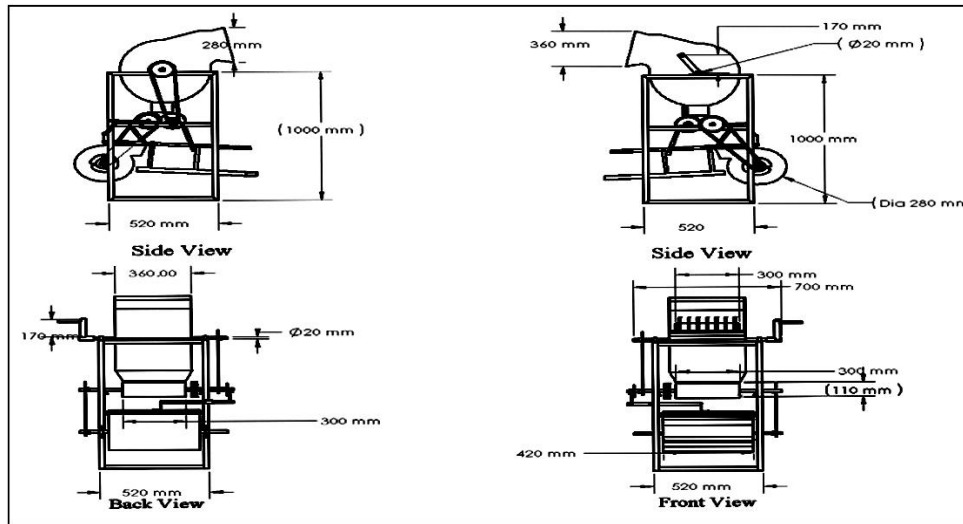

Fig. 1. Overall dimension of manually operated modified linseed crop thresher



Fig. 2. Physical properties in laboratory testing

2.1 Linear Seed Dimension

To figure out the size and shape of the linseed, the length, width, and thickness of 50 randomly chosen seeds from each variety were measured with a digital Vernier Calliper that had a minimum count of 0.01 mm. The average of these measurements was then written down.

$$AMD = \frac{L+B+T}{3}$$

$$GMD = (LBT)^{1/3}$$

where AMD is the arithmetic mean diameter (mm), GMD is the geometric mean diameter (mm), L is the length (mm), B is the breadth of the seed (mm), and T is the thickness of the seed (mm).

2.2 Surface Area

The surface area (S) was determined using the expression [5].

$$S = \pi(GMD)^2$$

2.3 Sphericity

Sphericity is defined as the ratio of the surface area of a sphere with the same volume as the grain to the surface area of the grain, and it was calculated using the formula below [2]. It is symbolized by the 'φ'.

$$\phi = \frac{(LBT)^{1/3}}{L}$$

2.4 Volume

The volume of the grain was calculated by taking the dimensions of the seed along three axes: length, breadth, and thickness, and then estimating volume using Mohsenin's relationship [2]. It is represented by the letter 'V.

$$V(\text{mm}^3) = \frac{\pi LBT}{6}$$

2.5 Thousand Grain Weight

A total of 1,000 randomly selected grains from varying moisture levels were collected and weighed on a digital scale with a minimum count of 0.01 g. This magnitude is known as the grain's thousand-grain weight. The average of five replications was taken into account and given as a sample weight of 1000 grains.

2.6 Bulk Density

The bulk density of a seed is the mass to total volume ratio. It was determined using the conventional test weight process, which consisted of filling a 250 ml graduated cylinder with a height of 12.5 inches, striking the top level, and weighing the contents (IS:4333 part III). Bulk density was then estimated as the ratio of the weight of the kernels to the volume of the cylinder [6,7].

$$BD = \frac{Ws}{Vs}$$

where BD = bulk density in kg/m³, Ws = sample weight in kg, and Vs = sample volume in m³.

2.7 True Density

The toluene (C7H8) displacement method was used to determine the real density, which is defined as the ratio of the sample's mass to its true volume. Toluene was used instead of water since it is less absorbed by seedlings. Toluene

(20 ml) was poured into a 40 ml graduated measuring cylinder, and 25 g of seeds were immersed in the toluene [7,8]. The amount of displaced toluene was measured using the cylinder's graduated scale. To figure out the real density, the weight of the seeds was divided by the amount of toluene that was moved.

Tvs =
(initial toluene level in the graduated cylinder)
– (final moisture level in the graduated cylinder)

$$TD = \frac{Ws}{Tvs}$$

Where TD represents true density in kg/m³, W_s represents seed weight in kg, and Tvs represents seed volume in m³.

2.8 Porosity

The porosity is the fraction of the bulk grain space that is not occupied by the grain. Using the equation, the porosity of the bulk seed was estimated using the actual density and bulk density measurements.

$$\epsilon = \frac{TD - BD}{TD} \times 100$$

Where, ε is the porosity; TD is the true density, kg/m³; and BD is the bulk density, kg/m³.

3. RESULTS AND DISCUSSION

3.1 Physical Properties of Linseed Capsule

Data presented in Table (1) show that the physical properties of a linseed capsule include the number of capsules per plant, the number of seeds per capsule, the length, width, and thickness of the capsule, and the Geometric Mean Diameter (GMD). The physical properties of linseed capsules.

Table 1. Physical properties of linseed capsules (N = 25)

Particular	Max.	Min.	Mean	SD (σ)	CV (%)
No. of linseed capsule per plant	41	30	36.88	2.619	7.101
No. of seed per capsule	10	6	8.12	1.129	13.914
Length of capsule (mm)	8.96	7.35	8.11	0.467	5.761
Width of capsule (mm)	7.79	6.05	6.946	0.440	6.346
Thickness of capsule (mm)	7.76	6.01	6.874	0.439	6.360
GMD (mm)	8.087	6.501	7.288	0.438	6.002

The average number of capsules per plant was found to be 36.88. The average number of seeds per capsule was found to be 8.12. Linseed's length, width, and thickness were measured to be 8.11, 6.94, and 6.87 mm, respectively. The geometric mean diameter measured 7.288 mm. There are no significant differences between the samples. Maurya et al. (2017) discovered a similar type of observation.

3.2 Moisture Content's Effect on Linear Dimensions of Linseed Varieties

The linear dimensions (length, breadth, and thickness) and AMD and GMD of two linseed seed varieties (Neelam and SHUATS Alsi-2)

were determined within the moisture content ranges of 7.47%, 10.78%, and 14.03%. Figs. 3 and 4 are provided.

The SHUATS Alsi-2 variety had an average length of 5.308mm, a width of 2.507mm, and a thickness of 0.964mm, whereas the Neelam variety had an average length of 5.214mm, a width of 2.448mm, and a thickness of 0.903. The SHUATS Alsi-2 variety had an average AMD of 2.924mm and a GMD of 2.338mm, whereas the Neelam variety had an average AMD of 2.855mm and a GMD of 2.258mm. Wang et al. [9] and Bhishe et al. [10] also found that the linear dimension and average diameter of linseed increase as the amount of moisture in the seed increases.

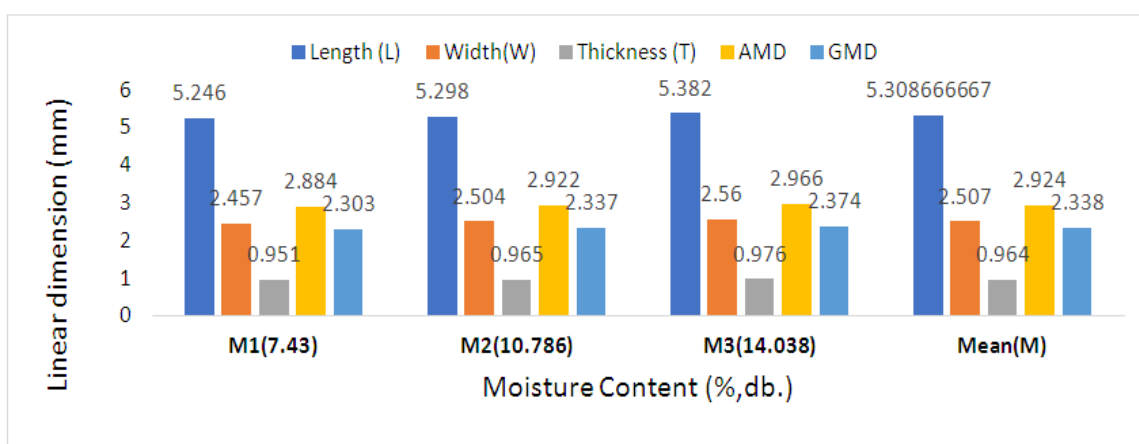

Fig. 3. Moisture content's effect on linear dimensions of linseed variety in SHUATS Alsi-2

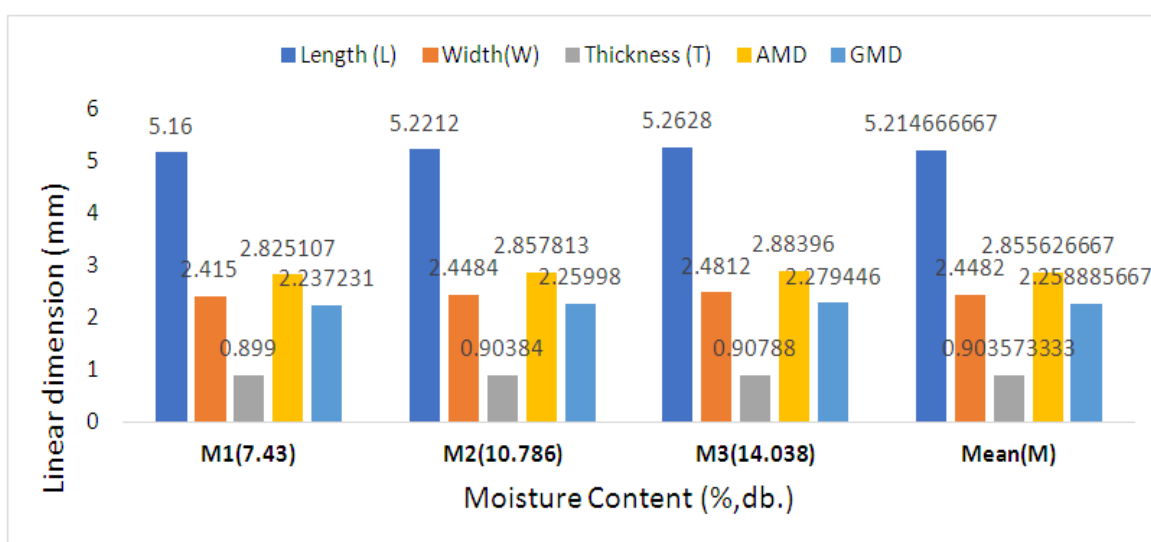

Fig. 4. Moisture content's effect on linear dimensions of linseed variety in Neelam

3.3 Moisture Content's Effect on Surface Area, Sphericity, Volume and 1000 Grain Weight of Linseed Varieties

The surface area, sphericity, volume, and 1000 grain weight of two linseed seed varieties, Neelam and SHUATS Alsi-2, were determined within the moisture content ranges of 7.47%, 10.78%, and 14.03%. It is located between Figs. 5 and 6.

The average surface area, sphericity, and volume for the SHUATS Alsi-2 variety were 17.218mm², 0.441, and 6.741mm³, respectively, whereas the average surface area, sphericity, and volume for the Neelam variety were 16.0403mm², 0.433, and 6.047mm³. It was also discovered that the mean 7.656gram thousand grain weight for the linseed variety in SHUATS Alsi-2 was lower than the mean 8.0153gram thousand grain weight for the linseed variety in Neelam. The observation of an increase in these linseed properties as moisture content increases agrees with the findings reported by Coskuner

and Karbaba [11], Bhishe et al. [10] and Wang et al. [9].

3.4 Moisture Content's Effect on Bulk Density, True Density and Porosity of Linseed Varieties

The bulk density, true density, and porosity of two linseed seed varieties, SHUATS ALSI-2 and Neelam, were determined within the moisture content ranges of 7.47%, 10.78%, and 14.03%. It is located between Figs. 7 and 8.

The SHUATS Alsi-2 variety had an average bulk density of 626.64 kg/m³, a true density of 1139.553 kg/m³, and a porosity of 44.847, whereas the Neelam variety had an average bulk density of 673.354 kg/m³, a true density of 1126.174 kg/m³, and a porosity of 40.135. The observed increase in linseed porosity with increasing moisture content is consistent with the findings reported by Coskuner and Karbaba [11]; Selvi et al. [12]; Bhishe et al. [10] and Wang et al. [9].

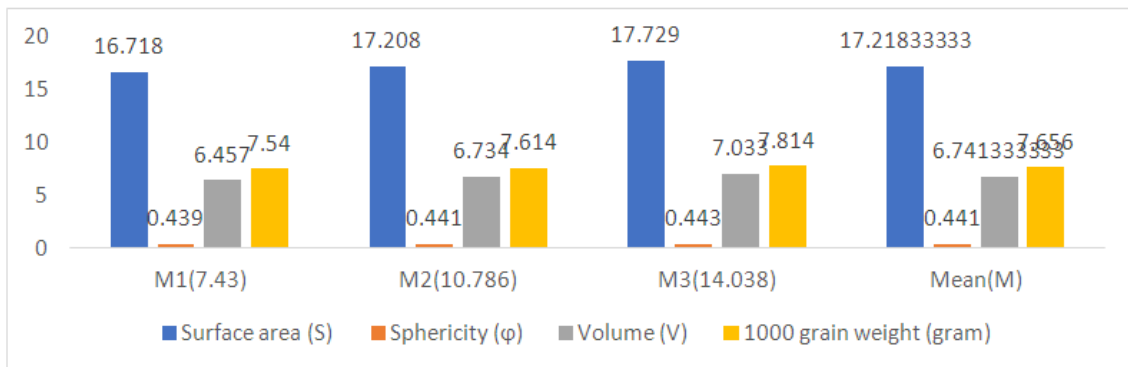

Fig. 5. Moisture content's effect on surface area, sphericity, volume and 1000 grain weight of linseed variety in SHUATS Alsi-2

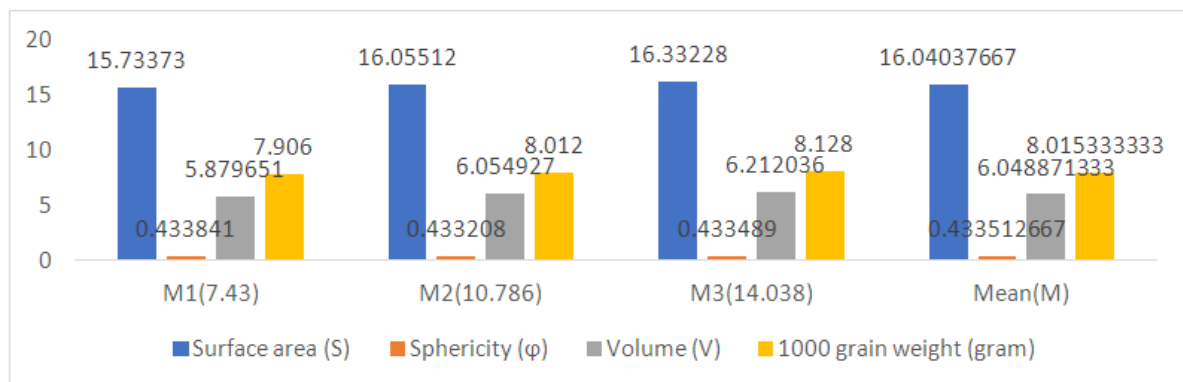

Fig. 6. Moisture content's effect on surface area, sphericity, volume and 1000 grain weight of linseed variety in Neelam

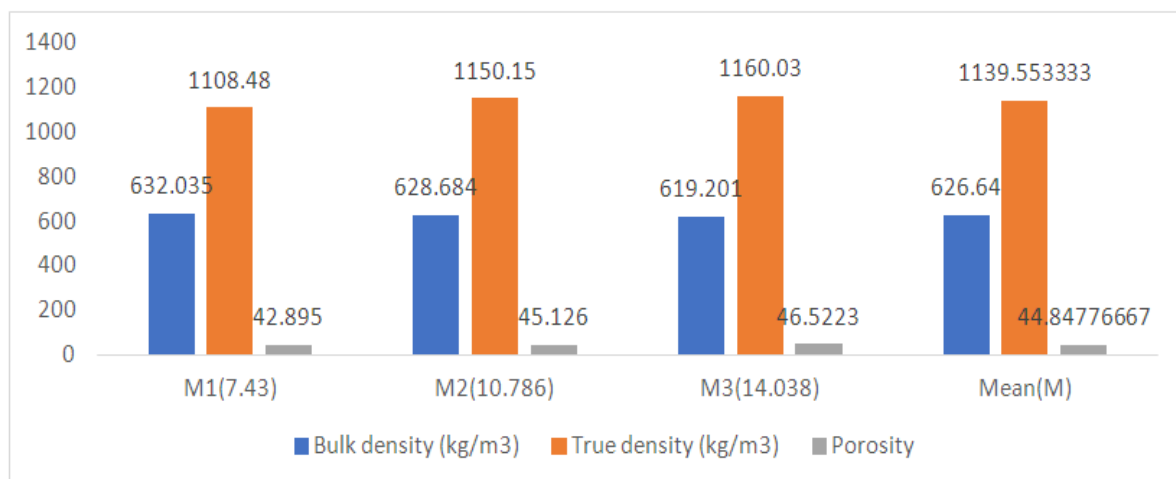

Fig. 7. Moisture content's effect on bulk density, true density and porosity of linseed variety in SHUATS Alsi-2

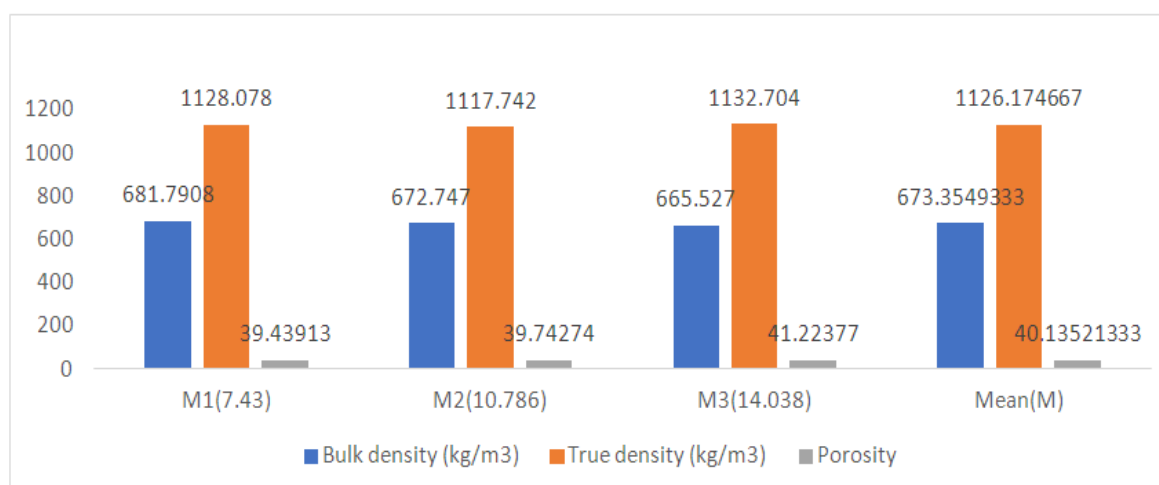

Fig. 8. Moisture content's effect on bulk density, true density and porosity of linseed variety in Neelam

4. CONCLUSION

1. The physical properties of the linseed capsule were the mean value of the number of capsules per plant, the number of seeds per capsule, length, width, the thickness of capsule, and GMD of 36.88, 8.12, 8.11mm, 6.94mm, 6.87mm, and 7.28mm [13-16].
2. Two varieties of SHUATS Alsi-2 and Neelam were discovered with moisture content ranging from 7.43% to 14.03%. Linseed seed linear dimensions (length, width, and thickness) were determined to be 5.308, 2.507, and 0.964mm for the SHUATS Alsi-2 variety and 5.214, 2.448, and 0.903mm for the Neelam variety. The mean GMD for the SHUATS Alsi-2 variety is 2.338mm, while the Neelam variety is 2.258mm [17-20].
3. The mean values of surface area, sphericity, volume, and TGW for the SHUATS Alsi-2 variety were 17.218mm², 0.441, 6.741mm³, and 7.656gram, respectively, whereas the Neelam variety was 16.04mm², 0.433, 6.047mm³, and 8.015gram.
4. The mean values of bulk density, true density, and porosity for the SHUATS Alsi-2 variety were 626.64 kg/m³, 1139.55 kg/m³, and 44.84, respectively, while the

Neelam variety was 673.354 kg/m³, 1126.17 kg/m³, and 40.135.

COMPETING INTERESTS

Authors have declared that no competing interests exist.

REFERENCES

1. Bozan B, Temelli F. Chemical composition and oxidative stability of flax, safflower and poppy seed and seed oils. *Bio Resour Technol.* 2008;99(14):6354-9.
2. Mohsenin NN. Physical properties of plant and animal materials. 2nd ed. New York: Gordon & Breach Science Publishers; 1986.
3. AACC. Approved methods. 10th Ed, moisture determination, Minnasota, St Paul. American Association of Cereal Chemists. 1995;44-15A.
4. Sacilink K, Ozturk R, Kesikin R. Some physical properties of hemp seeds. *Biosyst Eng.* 2002;86:191-8.
5. Singh KP, Mishra HN, Saha S. Moisture dependent properties of barnyard millet grain and kernel. *J Food Eng.* 2010;96(4):598-606.
6. Akaaimo DI, Raji AO. Some physical and engineering properties of *Prosopis africana* seed. *Biosyst Eng.* 2006;95(2): 197-205.
7. Mwithiga G, Sifuna MM. Effect of moisture content on the physical properties of three varieties of sorghum seeds. *J Food Eng.* 2006;75(4):480-6.
8. Oyelade OJ, Odugbenro PO, Abioye AO, Raji NL. Some physical properties of African star apple (*Chrysophyllum albidum*) seeds. *J Food Eng.* 2005;67(4):435-40.
9. Wang B, Li D, Wang L, Huang Z, Zhang L, Chen XD et al. Effect of moisture content on the physical properties of fibered flaxseed. *Int J Food Eng.* 2007;3(5):1-8.
10. Bhise S, Kour A, Manikantan AR. Engineering properties of flaxseed (LC 2063) at different moisture. *J Post-Harvest Technol.* 2013;01(01):52-9.
11. Coşkun Y, Karababa E. Some physical properties of flaxseed (*Linum usitatissimum* L.). *J Food Eng.* 2007;78(3):1067-73.
12. Selvi KÇ, Pınar Y, Yeşiloğlu E. Some physical properties of linseed. *Biosyst Eng.* 2006;95(4):607-12.
13. Coşkun MB, Yalçın İ, Özarslan C. Physical properties of sweet corn seed (*Zea mays saccharata* Sturt.). *J Food Eng.* 2006;74(4):523-8.
14. El Fawal YA, Tawfik MA, El Shal AM. Study on physical and engineering properties for grains of some field crops. *Misr J Agrol Eng.* 2009;26(4):1933-51.
15. Gupta RK, Das SK. Physical properties of Sunflower seeds. *J Agric Eng Res.* 1997;66(1):1-8.
16. Javad T, Asghar M, Naser A. Some mechanical and physical properties of corn seed (var. DCC 370). *Afr J Agric Res.* 2011;6(16):3691-9.
17. Mahmoudi A, Tarighi J, Alavi N. Some mechanical and physical properties of corn seed (var. DCC 370). *Afr J Agrol Res.* 2011;6(16):3691-9.
18. Patel G, Naik RK, Patel KishanK. Studies on some physical and engineering properties of linseed. *Biol Forum- An International Journal.* 2021;13(3):303-8.
19. Sharma S, Prasad K. Comparative physical characteristics of Linseed (*Linum usitatissimum*) Kernels. *Int J Agric Food Sci Technol.* 2013;4(7):671-8.
20. Singh AK, Sharma V, Yadav KC. Effect of moisture content on physical properties of flaxseed. *Research & Reviews. J Food Sci Technol.* 2014;3(2):19-27.

© 2022 Patel et al.; This is an Open Access article distributed under the terms of the Creative Commons Attribution License (<http://creativecommons.org/licenses/by/4.0>), which permits unrestricted use, distribution, and reproduction in any medium, provided the original work is properly cited.

Peer-review history:

The peer review history for this paper can be accessed here:
<https://www.sdiarticle5.com/review-history/92686>